

# Ttulpe

# C-Meister 12

Instructions for  
use, installation  
and maintenance



# Table of Contents

Introduction	3
Warning	5
General instructions	7
Operating instructions	8
Faults	10
Installations	11
Maintenance	15
Technical data and characteristics	16
Technical specifications	18
Declaration of conformity	20
Gas conversion instruction	21
Certificate of warranty - TTulpe®	22
Notes	24

# 1. Introduction

## Dear Buyer

We wish to congratulate you on the purchase of your TTulpe® gas water heater. It is safe to say that our gas water heaters will satisfy any of your needs. The use of modern technologies and high-quality materials in the manufacture of these devices brought popularity of and confidence in the TTulpe® trade mark.

TTulpe® electric water heaters are designed and manufactured in strict correspondence with international standards that ensure reliability and safety in operation. The models were all subjected to compulsory certification by the EU and fully comply with the requirements of Gas Appliance Directive 2009/142/EC. This Manual covers TTulpe® models (Series C-Meister). The model name of the water heater you purchased is shown in Section on "Manufacturer's Warranties" (Subsection on "Sales Mark") and on an identification plate on the device case.

## Water heater application

This water heater is designed for the purpose of heating potable water. Its use in an application other than this may shorten its life.

## Model type

TTulpe® C-Meister 12

The gas water heater model you have chosen can be installed indoor and is a 12 liters per minute model. The C-Meister is a modulating constant temperature water heater. Self-modulating flow sensor technology regulates the amount of energy required to heat the water needed.

The C-Meister is a direct vent, balanced flue, room sealed gas water heater. This is the safest type of gas water heaters because the fresh air inlet comes from outside and the exhaust gasses are pushed outside.

The temperature is controlled by thermostats. Automatic safety controls are fitted to the water heater to provide safe and efficient operation.

A hardware pack with screws and fittings is included to make the installation easier.

## Mains pressure

The water heater is designed to operate at mains pressure by connecting directly to the mains water supply. The supply pressure should be greater than 0,5 Bar for true mains pressure operation to be achieved.

## How hot should the water be?

The water heater has a minimum temperature setting of 30°C and a maximum thermostat setting of 60°C .

## Hotter water increases the risk of scald injury

This water heater can deliver water at temperatures which can cause scalding. Check the water temperature before use, such as when entering a shower or filling a bath or basin, to ensure it is suitable for the application and will not cause scald injury .

## Use and care

The purpose of this manual is twofold; one, to provide the installer with the basic directions and recommendations for the proper installation and adjustment of the water heater, and two, to the owner operator, to explain the features, operation, safety precautions, maintenance and troubleshooting of the water heater. It is imperative that all persons who are expected to install, operate, or adjust this water heater read the instructions carefully so they may understand how to perform these functions. If you do not understand these instructions or any terms within, seek professional advice. Any questions regarding the operation, maintenance service or warranty of this water heater should be directed to TTulpe B.V. or one of its International Distributors directly.

Netherlands/France/Germany/UK/Belgium: KIIP B.V., +49(0)39292678219, info@kiip.de  
Do not destroy this manual. Please read carefully and keep in a safe place for future reference.

## 2. Warning

**WARNING:** If the information in these instructions is not followed exactly, a fire or explosion may result causing property damage, personal injury or death.

**WARNING:** Always use a professional and knowledgeable installer.

**WARNING:** Installation requirements may vary from country to country.  
TTulpe or its resellers assume no liability for improper use or installation.

### Important safety information read all instructions before using

Be sure to read and understand the entire Use and Care Manual before attempting to install or operate this water heater. It may save you time and money. Pay particular attention to the Safety Instructions. Failure to follow these warnings could result in serious bodily injury or death. Should you have problems understanding the instructions in this manual, or have any questions, STOP, and get help from a qualified service technician, or the local gas utility.

### Danger!

#### Properly install water heater

Failure to properly install the water heater indoors as outlined in the Installation Instructions in this manual can result in unsafe operation of the water heater. To avoid the risk of fire, explosion, or asphyxiation from carbon monoxide, never operate this water heater unless it is installed properly and has an adequate air supply for proper operation. Be sure to inspect the flue terminal for proper installation at initial start-up; and at least annually thereafter. Refer to the Care and Cleaning section of this manual for more information regarding flue terminal inspection. The water pressure shall not exceed 8 bar.

### Warning

Gasoline, as well as other flammable materials and liquids (adhesives, solvents, paint thinners etc.) and the vapors they produce are extremely dangerous. DO NOT handle, use or store gasoline or other flammable or combustible materials any where near or in the vicinity of a water heater or any other appliance. Be sure to read and follow the labels on the water heater, as well as the warnings printed in this manual. Failure to do so can result in property damage, bodily injury or death.



Vapors from flammable liquids will explode and catch fire causing death or severe burns.

Do not use or store flammable products such as gasoline, solvents or adhesives in the same room or area near the water heater.

### Keep flammable products:

1. Far away from heater
2. In approved containers
3. Tightly closed
4. Out of children 's reach

### Water heater has a main burner flame.

#### The main burner flame

1. Can come on at any time and
2. Will ignite flammable vapors.

### Vapors:

1. Cannot be seen
2. Are heavier than air
3. Go a long way on the floor
4. Can be carried from other rooms to the main burner flame by air currents. Installation:

Read and follow water heater warnings and Instructions. If owners manual is missing, contact the retailer or manufacturer.

### Danger!

#### Propane/butane and natural gas models

LP or NG has an odorant added to aid in the detecting a gas leak. Some people may not physically be able to smell or recognize this odorant. If you are unsure or unfamiliar with the smell of LP/NG, ask the gas supplier. Other conditions such as "odorant fade", which causes the odorant to diminish in intensity, can also hide or camouflage a gas leak.

- Water heaters utilizing LP gas are different from natural gas models. A Natural gas water heater will not function safely on LP gas and vice versa
- No attempt should ever be made to convert the water heater from LP gas to NG and vice versa. To avoid possible equipment damage, personal injury, or fire, do not connect the water heater to a fuel type not in accordance with the data plate.
- LP gas must be used with great caution. It is heavier than air and will collect first in lower areas making it hard to detect at nose level.
- Before attempting to light the water heater, make sure to look and smell for gas leaks. Use a soapy solution to check all gas fittings and connections. Bubbling at a connection indicates a leak that must be corrected. When smelling to detect a gas leak, be sure to sniff near the floor also.
- Gas detectors are recommended in LP and NG applications and their installation should be in accordance with the detector manufacturer's recommendations and/ or local laws, rules, regulations or customs.

1. If the smell of gas is detected, turn off the gas valve at the tank or the main valve in your gas supply immediately! Do not use flame for leak detection.

2. For indoor use only

# 3. General instructions

- Carefully read and follow the instructions contained in this booklet.
- After installing the unit, inform the user about its operation and give him this manual, which is an integral and essential part of the product and must be kept for future reference.
- Installation and maintenance must be carried out by professionally qualified personnel, in compliance with the current regulations and according to the manufacturer's instructions. Do not carry out any operation on sealed adjustment parts.
- Incorrect installation or inadequate maintenance can result in damage or injury. The Manufacturer declines any liability for damage due to errors in installation and use, or failure to follow the instructions.
- Before carrying out any cleaning or maintenance operation, turn off the gas by means of the special shutoff devices.
- In case of a fault and/or poor operation, deactivate the unit and do not try to repair it or directly intervene.
- Contact professionally qualified personnel. Any repair/replacement of the products must only be carried out by qualified personnel using original replacement parts. Failure to comply with the above could affect the safety of the unit.
- This unit must only be used for its intended purpose. Any other use is deemed improper and therefore hazardous.
- The packing materials are potentially hazardous and must not be left within the reach of children.
- The unit must not be used by people (including children) with limited physical, sensory or mental abilities or without experience and knowledge of it, unless instructed or supervised in its use by someone responsible for their safety.
- The unit and its accessories must be appropriately disposed of, in compliance with the current regulations.
- The images given in this manual are a simplified representation of the product. In this representation there may be slight and insignificant differences with respect to the product supplied.
- For long periods of inactivity during the winter months, to avoid frost damage it is advisable to drain all the water from the water heater. Proceed as follows: Remove the drain valve located at the incoming water connector (release valve, page 16,17). Empty the appliance of all water.
- Frost protection when the temperature of the hot water sensor is below 5 ° C. If the water heater is not blocked, the burner is activated; the performance of the Burner adjusts to a minimum, after it has ignited. In shutdown mode the screen shows the flame symbol that indicates the presence of the flame.

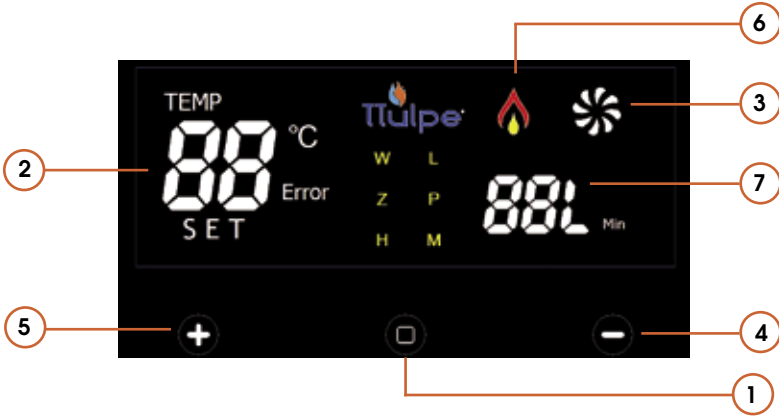

# 4. Operating instructions

## 4.1. Control panel



- 1 on/off button
- 2 DHW temperature display / Error code display
- 3 Fan display
- 4 Temperature adjustment low
- 5 Temperature adjustment high
- 6 Flame symbol Indication during operation
- 7 Actual Water flow (liters per minute)

### Display symbols

Display Symbols	
	Symbol flashing: the burner is on. If the burner is off, this symbol is not displayed.
	Water heater outlet temperature.
WZH	Water flow too high, desired temperature cannot be reached
LPM	Liters per minute
ERROR	Error
SET	Set temperature
	Rotating symbol. Heater working, normal operation.



## Lighting and turning off | Connection to the power supply

1. Open the gas cock ahead of the unit.
2. The unit is ready to function automatically whenever hot water is drawn.
3. Turning the unit off and lighting
4. Press the on/off button for 1 second.

### 4.2. Adjustments

#### Temperature setting

Domestic hot water (DHW) temperature adjustment

Use the DHW buttons fig. 1 (details 4 and 5 - ) to adjust the temperature from a min. Of 30°C to a max. of 60°C.

When the unit is turned off, the electronic board is still powered. DHW mode is disabled. The antifreeze system remains activated. To relight the unit, press the on/off button again for 1 second.

The unit will be immediately ready to work whenever hot water is drawn. The antifreeze system does not work when the power and/or gas to the unit are turned off. To avoid damage caused by freezing during long idle periods in winter, it is advisable to drain all the water from the water heater.

If the sign WZH lights up, too much water is flowing through the water heater. You can adjust the flow with the Water flow reduce cock on the cold water inlet. (Water flow adjustive valve, page 17).

# 5. Faults

After making the adjustments described above, the water heater is ready to operate in completely automatic mode. When a hot water tap is opened, an intermittent discharge is generated on the ignition electrode, which causes lighting of the burner and, at the same time, operates the gas extraction fan.

All the electronic models have an ionisation electrode inserted in the burner to control correct flame presence. In case of malfunction or no gas with subsequent burner shut down, close the hot water tap.

It is then necessary to eliminate the cause or the element preventing the gas from reaching the water heater, e.g. inadvertent closing of the gas cock, empty gas cylinder, etc.

Water heater shutdown status is deactivated by closing and opening the hot water tap. Repeat the operation if the delivery of hot water is not restored after eliminating the cause and opening the hot water tap. If the fault persists, contact the After-Sales Technical Service.

Table of faults

E0	Error for output water temperature sensor. Sensor isn't working properly.
E1	Error for Ignition failure.
E2	False calls, the water heater senses flame before ignition.
E3	Error on thermostat, the thermostat isn't working properly.
E4	Error on temperature sensor of cold water.
E5	Fan error, fan or air pressure switch is not working correctly.
E6	Enabled protection for over temperature, when hot water temperature is over 85 degrees Celcius for more than 3 seconds, the water heater shuts off.

During a DHW demand (generated by drawing domestic hot water), the display shows the actual DHW outlet temperature and water flow.

# 6. Installations

## 6.1 General instructions

The water heater must only be installed by qualified personnel, in compliance with all the instructions given in this technical manual, the provisions of current law, the national and local regulations, and the rules of proper workmanship.

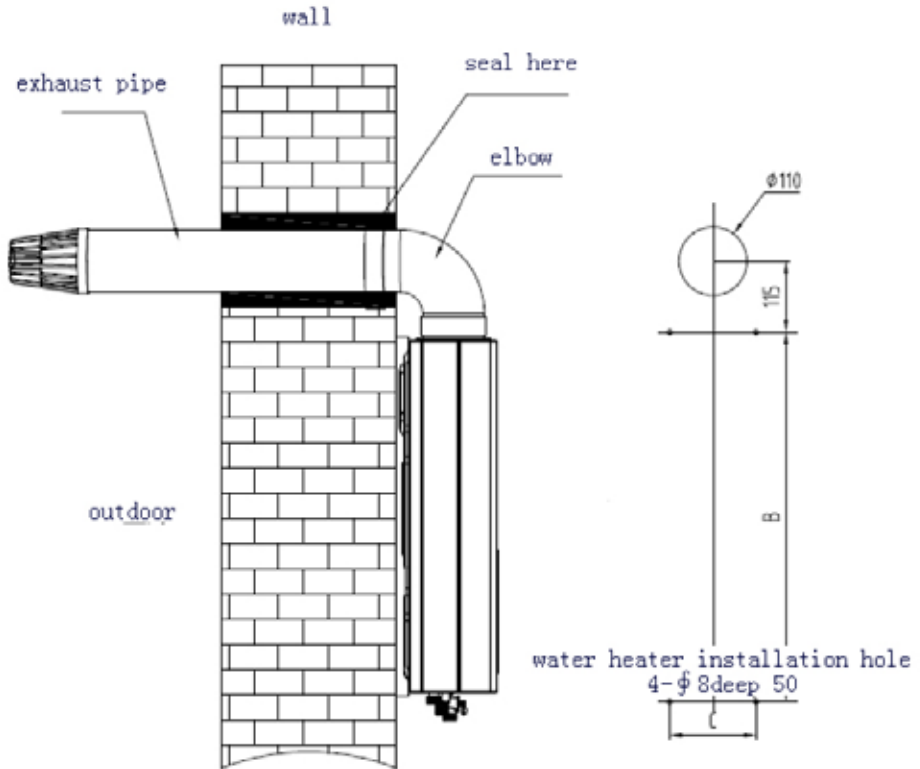

Example of installation on the wall with horizontal concentric flue.

## 6.2 Place of installation

The combustion circuit is airtight as regards the installation environment, so the unit can be installed in any room. However, the place of installation must be adequately ventilated to avoid dangerous situations in the event of a gas leak. The directive CE 90/396 sets the safety standard for all gas powered equipment, including those with an airtight chamber.

The unit is suitable to operate in a partially protected place, in accordance with standard EN 297 amendment A6, with temperatures no lower than -5°C.

In any case, the place of installation must be free of dust, flammable materials or objects or corrosive gases. The unit can be hung on the wall.

If the unit is enclosed in a cabinet or mounted alongside, a space must be provided for removing the casing and for normal maintenance operations. The minimum clearance between any inflammable materials and the water heater is 50 mm.

If the water heater is mounted on walls that are sensitive to heat, for example wood, the wall shall be protected with a suitable insulation. The clearance between the wall on which the appliance is installed and the hot parts on the outside of the appliance must be observed.

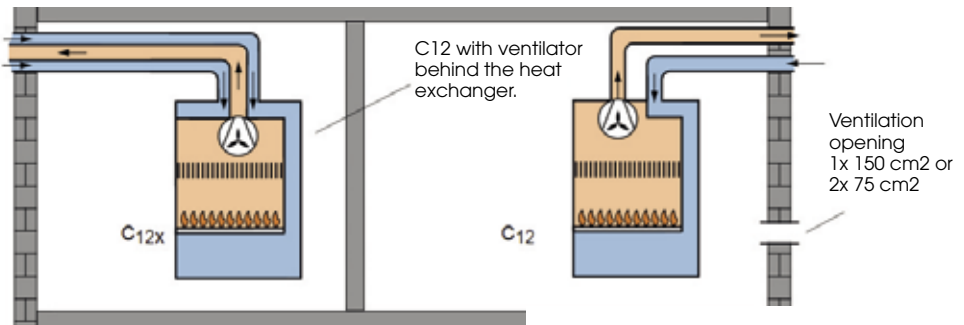

Installation type C12 and C12x

## 6.3 Plumbing connections

### Important

Before making the connection, check that the unit is arranged for operation with the type of fuel available and carefully clean all the system pipes. Carry out the relevant connections according to the symbols given on the unit .

In the presence of water harder than 25° Fr (1°F = 10ppm CaCO<sub>3</sub>), use suitably treated water in order to avoid possible scaling in the water heater.

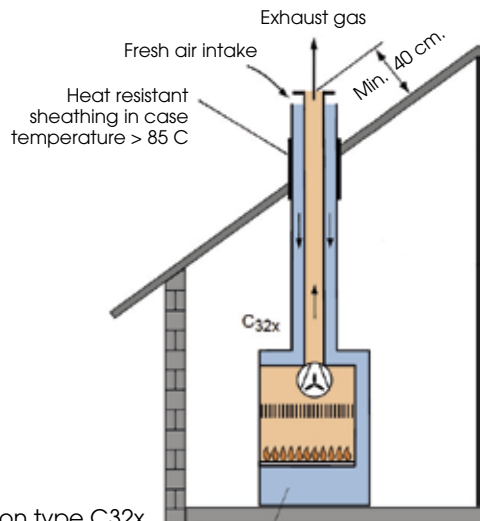

Installation type C32x

### 6.4 Gas connection

The gas must be connected to the respective union (see figure on cover) in conformity with the current regulations, with a rigid metal pipe or with a continuous flexible s/steel tube, installing a gas cock between the system and water heater. Make sure all the gas connections are tight.

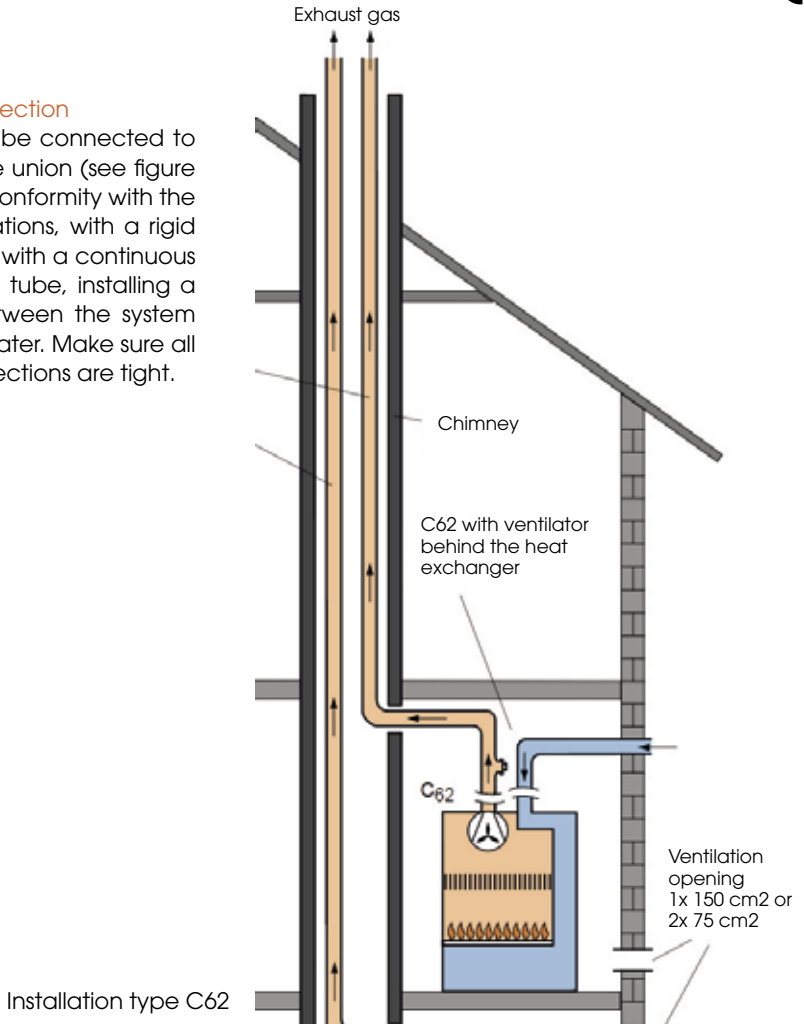

### 6.5 Electrical Connections

#### Warning

The unit must be connected to an effective earth connection, as stated in the safety rules. Ask a qualified technician to check the efficiency and compatibility of the earth installation. The manufacturer accepts no responsibility for damage caused by a lack of earth connection for the unit.

The heater is supplied with a cable to connect it to the electrical network, Y-type with a pin. The supply cable for the unit must not be replaced by the user. If the cable is damaged, turn off the unit and call an authorised technician to replace it. For the replacement, only use cable HAR H05 VV-F measuring 3x0.75mm<sup>2</sup> with an external diameter of a maximum of 8mm.

## 6.6 Fume duct

### Warning

The unit is type C with an airtight chamber and forced ventilation, the air inlet and steam outlet must be connected to systems like those subsequently indicated. The unit is approved for operation with all configurations of Cny chimneys shown on the technical data sheet. However, it is possible that some configurations may be limited or prohibited by local laws, standards or regulations. Before carrying out the installation, check and strictly adhere to the relevant regulations. Also comply with provisions regarding the position of terminals on the wall or roof and the clearances between windows, walls, ventilation openings etc.

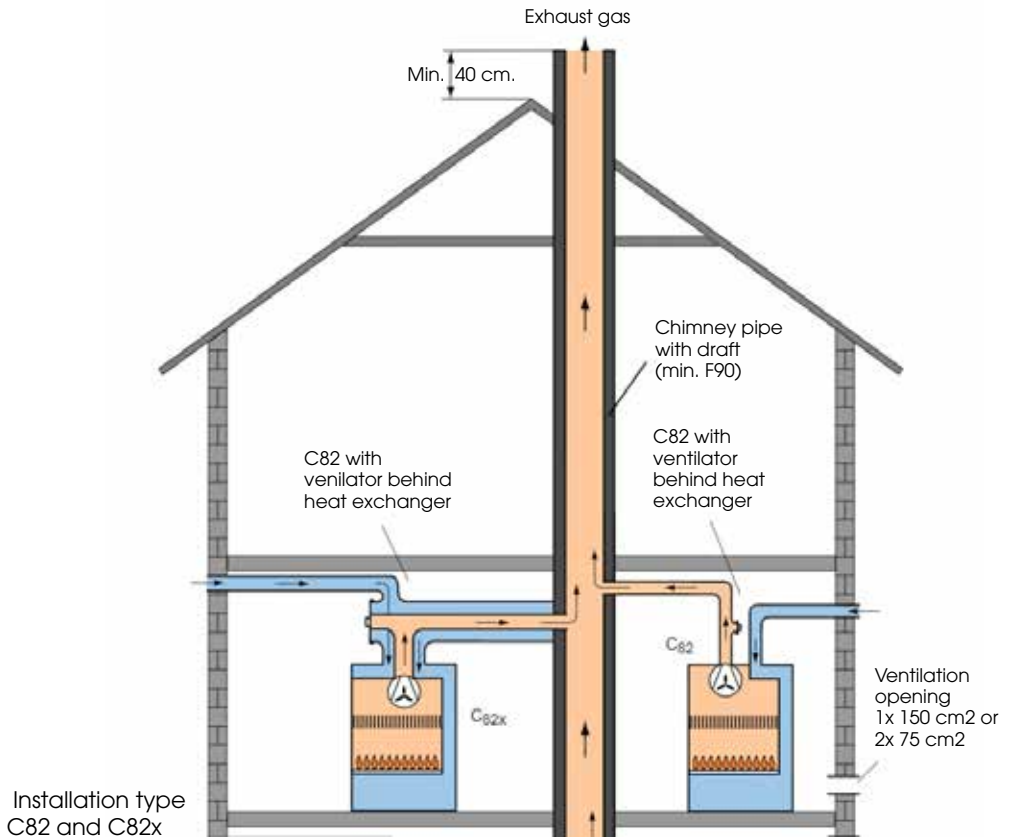

## 6.7 Installing the flue pipe

- The flue pipe must extend to the outside, whose termination must be 50 cm away from any obstructions and 5 cm away from the wall.
- If the flue pipe goes through any flammable wall, it must be wrapped in a layer of fire-resistant insulation, thicker than 2 cm.
- The flue pipe must be attached with a windscreen at the outlet. The outlet must be free and not be covered with anything.
- The maximum length of the concentric flue pipe is 10 m. subtract one meter from each bend used in the flue pipe.
- The terminal guard is fixed on the flue pipe. Don't remove the terminal guard.
- Terminal outlets from separate ducts shall fit inside a square of 50 cm.
- The water heater is not intended to be connected to flues that are likely to be affected by heat (e.g. plastic ducts or ducts with internal plastic coatings).

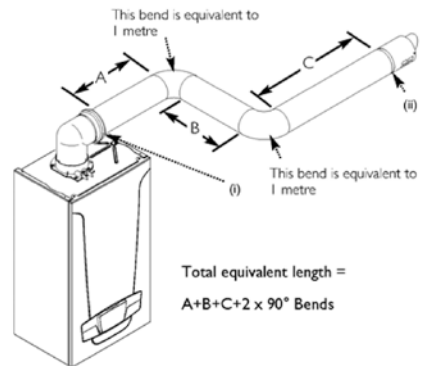

# 7. Maintenance

## Opening the casing

To open the water heater casing:

1. Undo the screws at the top and bottom
2. Take the casing off carefully.
3. Disconnect the display connector and unplug the water heater.

Close the gas cock upstream before carrying out any operation inside the water heater.

## Periodical inspection

To ensure proper operation of the unit over time, have qualified personnel carry out a yearly inspection, providing for the following checks:

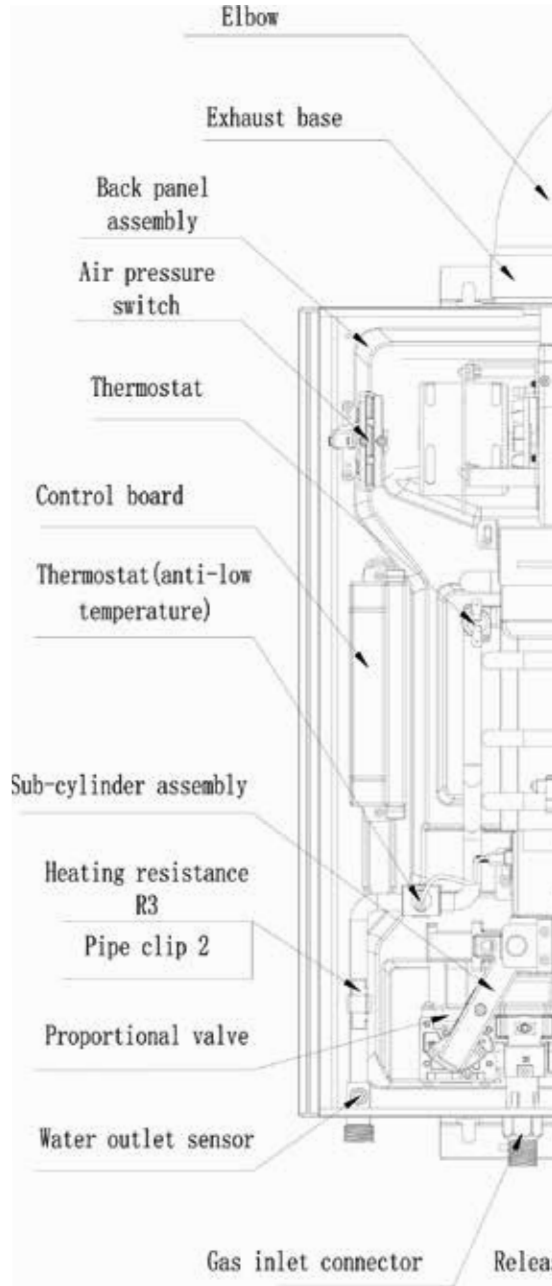

- The control and safety devices must work properly.
- The fume exhaust circuit must be perfectly efficient.
- The fume ducts and terminal must be free of any obstacles and leaks
- The burner and exchanger must be clean and free of deposits. For possible cleaning, do not use chemical products or wire brushes.
- The electrodes must be free of deposits and correctly positioned.
- The gas and water systems must be tight.
- The gas flow and pressure must match that given in the respective tables.

# 8. Technical data and characteristics



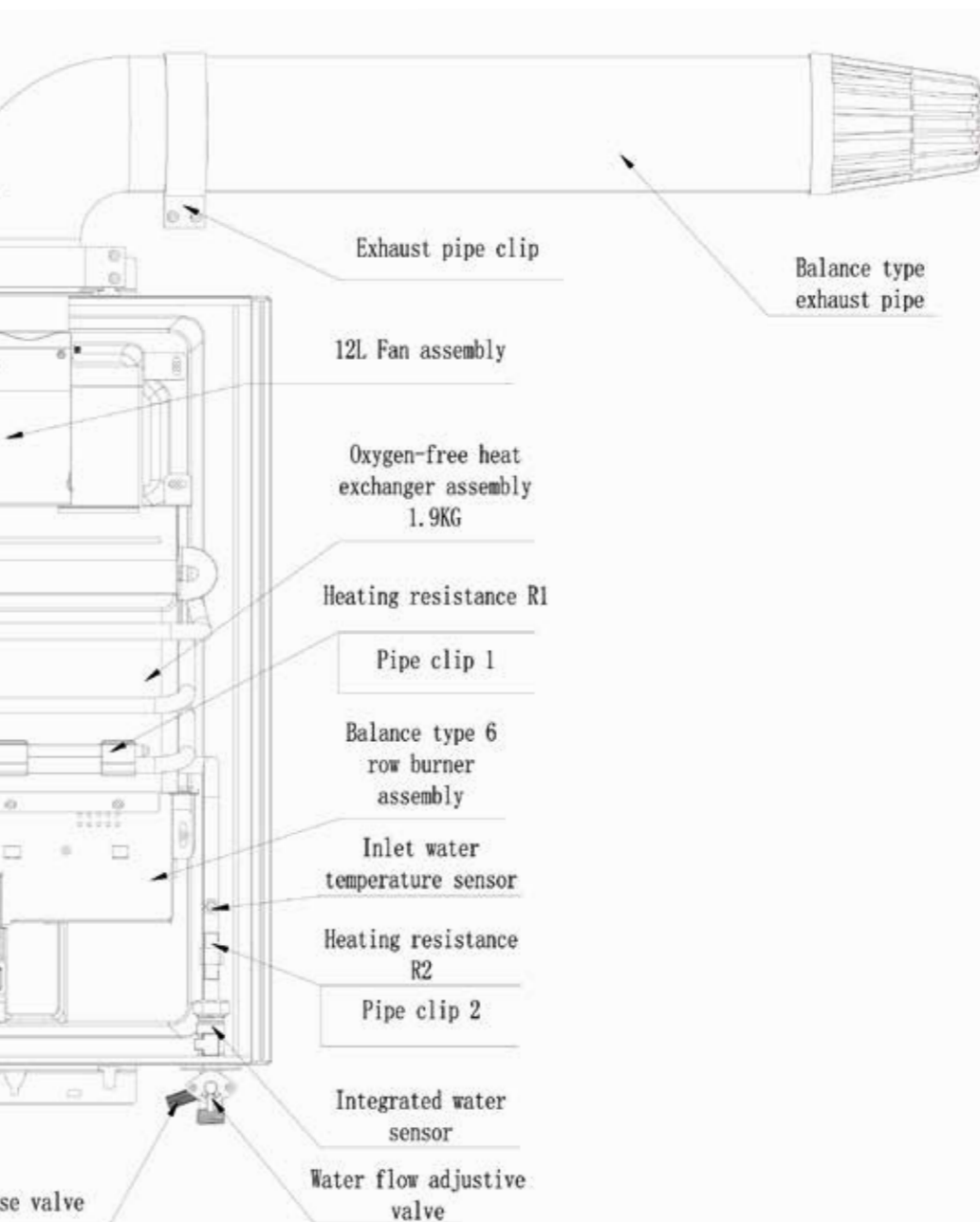



Appliance name					
Trade name					
Type					
Gas Category	$I_{3+(28-30/37)} \checkmark$		$I_{3B/P(30)}$	$I_{3B/P(37)}$	
Model	C-Meister 12 P30		C-Meister 12 P30	C-Meister 12 P37	
Gas Type	Butane	Propane	Butane, Propane or their mixtures	Butane, Propane or their mixtures	Butane, Propane or their mixtures
Gas Pressure	28-30 mbar	37 mbar	28-30 mbar	37 mbar	
Countries of Destination	BE, FR, IT, LU, LV, IE, GB, GR, PT, ES, CY, CZ, LT, SK, CH, SI		LU, NL, DK, FI, SE, CY, CZ, EE, LT, LV, MT, SK, SI, BG, IS, NO, TR, HR, RO, IT, HU	PL	
Nozzles quantity					
Nozzle diameter in mm.	1,2		1,2	1,2	
Nozzle rated pressure in mbar	30		30	37	
Nominal heat input Qn kW					
The nominal useful output Pn kW					
The Minimum heat input Qm kW			6.5 kW	7 kW	
The Minimum useful output Pm kW			5.8 kW	6.5 kW	
Nominal heat efficiency					
Gas Consumption					
NG (G20) in m3/h					
LPG (G30) in kg/h	1,15		1,15	1,15	
Flue gas average temperature					
Hot water data					
Nominal water flow rate					
Cold inlet water is 15°C, water temperature of maximum flame can reach					
Cold inlet water is 15°C, water temperature of minimum flame can reach					
Minimum water pressure Pw					
Maximum water pressure Pw					
Connectors' data					
Water pipe connector					
Gas pipe connector					
Flue diameter					
Flue length min. / max.					
Electrical Voltage					
Dimension / Weight					
Width x Height x Depth					
Weight					
Country of Origin					
Manufacturer	TTulpe B.V.				
 <b>2531-17</b> Pin Code: 2531CS0049					

TTulpe Balanced Type Gas Fired Water Heater				
TTulpe®				
C12				
I <sub>3B/P(50)</sub>	I <sub>2H(20)</sub>	I <sub>2E(20)</sub>	I <sub>2E+</sub>	I <sub>2EK</sub>
C-Meister 12 P50	C-Meister 12 N20-E	C-Meister 12 N20-E	C-Meister 12 N20-E	C-Meister 12 N25
butane, Propane or their mixtures	Natural Gas	Natural Gas	Natural Gas	G20, G25.3
50 mbar	20 mbar	20 mbar	20 mbar	20 mbar for G20; 25 mbar for G25.3
DE, AT, CH, LU, SK	FR, IT, DK, IE, GB, GR, ES, PT, AT, FI, SE, CZ, EE, HU, LV, LT, SK, SI, IS, NO, CH, TR, HR, RO	DE, LU, PL, NL	BE, FR	NL
6				
1,2	1,58	1,58	1,58	1,58
50	20	20	20	20/25
24 kW				
21 kW				
7.5 kW	8.8 kW			
6.5 kW	7.5			
> 84 %				
1,15	2,54	2,54	2,54	2,54
165 °C				
12 l/min				
65 °C				
35 °C				
1 bar				
8 bar				
G 1/2" Inch				
G 1/2" Inch				
60/100 mm.				
0,67/10 m.				
220-240 V, 50Hz, 75W				
380x 630 x 160 mm.				
10 kg				
Made in P.R.C.				
Chamber of commerce number: 63667479				

# 9. EU-Declaration of conformity

We

**Manufacturer's Name:** TTulpe B.V.

**Manufacturer's Address:** Wester Boekelweg 21a, 1718 MJ Hoogwoud, The Netherlands  
Chamber of commerce number: 63667479

Here with declare that this product

**Product:** TTulpe Balanced type gas fired water heater.

**Model(s) / Type(s):** C-Meister 12 N20-E, C-Meister 12 N25,  
C-Meister 12 P30, C-Meister 12 P37, C-Meister 12 P50

**Trademark:** TTulpe®      **Serial number:** ---

is in conformity with the following EC directives:

- Gas Appliance Directive (2009/142/EC)
- Low Voltage Directive (2014/35/EU) and
- EMC-directive (2014/30/EU)

and that the following harmonized standards have been applied:

- Relevant harmonised gas appliance standards:  
EN 26: 2015, EN 298: 2012
- Relevant harmonised LVD standards:  
EN 60335-2-102: 2006+A1: 2010  
EN 60335-1: 2012+A11: 2014  
EN 62233: 2008
- Relevant harmonised EMC standards:  
EN 55014-1: 2006+A1: 2009+A2: 2011  
EN 55014-2: 1997+A1: 2001+A2: 2008  
EN 55014-2: 2015  
EN 61000-3-2: 2014  
EN 61000-3-3: 2013

**The Notified Body who has performed EC Type Examination:**

EC Type Examination Certificate: 2531CS0049

Notified Body: DBI-C

Notified Body no.: 2531

TTulpe B.V.

Hoogwoud

05-09-2017



Sándor Körössy  
Directeur TTulpe B.V.

# 10. Gas conversion instruction

**Warning: it is not possible to convert the water heater to another type of gas. For example from propane to natural gas or vice versa. This instruction should only be performed by qualified installers, the importer or the designated service points of Ttulpe®. Ttulpe® and its importers are not liable for any consequences from the improper execution of the following instruction.**

To convert the water heater to another gas pressure in the same kind of gas, follow the instructions below:

When the electric power is on, press the buttons 4 and 5 (see pic. 4.1. page 8) on the control panel at the same time for about 3 seconds, → turn to gas code selection " FA " option. → press button 1 (see pic. 4.1. page 8) and turn to gas code adjustment. → press button 4 or 5 to choose gas code to choose the gas type you want. → press button 1 to confirm, return to gas code selection " FA " option. → press button 5 several times until you see " qU " option. → press button 1 to save it and exit.

Codes for different gas type as below:

- |    |                      |               |
|----|----------------------|---------------|
| 1. | I3B/P(30), I3+       | FA code is 00 |
| 2. | I2EK, I2H, I2E+, I2E | FA code is 01 |
| 3. | I3B/P(37)            | FA code is 02 |
| 4. | I3B/P(50)            | FA code is 03 |

# Certificate of warranty – TTulpe®

TTulpe® guarantees appliances that it supplies in accordance with European directive 1999/44/EC guaranteeing the sale of Consumer Goods for a period of two years against a lack of conformity appearing after delivery of the product.

Unless proven otherwise, it will be assumed that any lack of conformity that appears in the six months from the delivery did not exist when the goods were delivered.

The warranty for spare parts will have a duration of two years from the date of delivery of the equipment.

This guarantee is only and exclusively valid for equipment sold and installed on EU territory.

## Scope of the warranty

Unless proven otherwise, it is understood that the goods comply with and are suitable for the purpose for which they were purchased, and are always used under the following conditions:

- The guaranteed equipment must correspond to the equipment that the manufacturer expressly intends for the country of destination, and must be installed in that country.
- The necessary spare parts will be those determined by our OFFICAL Technical Department, and in all cases will be TTulpe original parts.
- The warranty is valid provided that the normal maintenance operations, described in the technical instructions supplied with the equipment, are carried out.
- The consumer must inform TTulpe of a lack of conformity within a period of less than two months after discovering it.

## The warranty does not cover incidents caused by:

Freezing, although it can be that your device is equipped with an anti-freeze protections, is any damage due to frost out of warranty.

- The electrical supply of equipment by generators or any other system that is not a stable electrical network with sufficient capacity.
- Products that have undergone any repair not carried out by TTulpe's OFFICAL Technical Department and/or personnel authorised by TTulpe.
- Corrosion, deformation, etc., caused by inadequate storage.
- Handling of the product by anyone outside of TTulpe during the warranty period.
- Assembly not in accordance with the instructions supplied with the equipment.
- Installation of the equipment that does not respect the Laws and Regulations in force (electricity, hydraulics, etc.).
- Defects in the electric or hydraulic facilities, or due to insufficient flow etc.
- Faults caused by the incorrect treatment of supply water to the equipment, by corrosion originating from water hardness, by poorly carried out descaling treatments etc.

- Faults caused by atmospheric agents (ice, lightning, floods etc.) as well as by erratic currents.
- Inadequate maintenance, neglect or improper use.

The material replaced under warranty will remain the property of TTulpe®

NOTE: It is essential to complete all of the information requested in the Certificate of Warranty. The validation of the warranty must be done immediately, by filling in the date and sending it immediately to TTulpe B.V. All of our OFFICIAL Technical Departments have the corresponding accreditation from TTulpe®. Request this accreditation for any intervention.

Potential claims must be made to the competent authority in this matter.









TTulpe®  
Wester Boekelweg 21a  
1718 MJ Hoogwoud  
Netherlands

Tel: 0031 (0)226 428877  
Email: [info@ttulpe.com](mailto:info@ttulpe.com)